

# Wireless Based System for the Continuous Electrocardiography Monitoring During Surgery

K. Bensafia<sup>1,2</sup>, A. Mansour<sup>2</sup>, G. Le Maillot<sup>2</sup>, B. Clement<sup>2</sup>, O. Reynet<sup>2</sup>, P. Ariès<sup>3</sup> and S. Haddab<sup>1</sup>

**Abstract**—This paper presents a system designed for the wireless acquisition, the recording of electrocardiogram (ECG) signals and the monitoring of the heart's health during surgery. This wireless recording system allows us to visualize and monitor the state of heart's health during a surgery even if the patient is moved from the operating theater to post anesthesia care unit. The acquired signal is transmitted via a Bluetooth unit to a PC where the data are displayed, stored and processed. To test the reliability of our system, a comparison between ECG signals processed by a conventional ECG monitoring system (Datex-Ohmeda) and by our wireless system is made. The comparison is based on the shape of the ECG signal, the duration of the QRS complex, the P and T waves, as well as the position of the ST segments with respect to the isoelectric line. The proposed system is presented and discussed. We have confirmed that the use of Bluetooth during surgery does not affect the devices used and vice versa. Pre and post processing steps are briefly discussed. Experimental results are also provided.

**Keywords**— Electrocardiography, Monitoring, Surgery, Wireless System.

## I. INTRODUCTION

IN order to ensure the continuous, uninterrupted monitoring of a patient in a hospital, electronic devices play a very important role, specially in the intensive care. Up to now, in surgery, wired biomedical sensors are widely used for monitoring of physiological elements such as: electrocardiogram (ECG) and arterial and venous blood pressure, etc. Moving a patient from operating to recovery rooms requires the release of all monitoring systems which can be dangerous for the patient. To address this problem, researchers are thinking of replacing wired with wireless sensors.

A wireless transmission is becoming increasingly popular in healthcare and biomedical engineering. In order to reduce the number of wires attached to patients and to facilitate their transportation and, also to ease early ambulation of the patient

in the intensive care unit or intermediate care environment, wireless biomedical sensors are recommended [1]. In this context, the authors of [2] proposed a device of a single channel ECG homecare using AD8232 circuit. An electrocardiogram acquisition system based on pairing of FPAA and FPGA devices is proposed in [3]. The MSP430 and USB technologies have been employed to design the Holter ECG system [4]. To monitor the physiological variables of a patient's ECG outside of hospital environments, a wireless system based on the microcontroller 16F876 is proposed [5]. In order to monitor the EEG signal remotely, the authors in [6] [7] have constructed a wireless EEG acquisition system that allows monitoring the patients.

Although the use of wireless systems is highly replicated in the biomedical field, they are not recommended in the operating theater. The main reason is to limit and control electromagnetic interferences. Recently, few studies show up that the use of wireless devices in operating rooms is possible. The authors of [1] developed a continuous monitoring system for arterial pressure during surgery. This was motivation to design a wireless monitoring system.

In this work, our system allows real time acquisition, recording and monitoring of ECG signals using Bluetooth protocol during surgery. The system used three skin electrodes, attached to the AD8232-EVALZ [8] circuitry. The reliability of our system, is showed up by comparing the ECG signals of a conventional device and those captured by our system.

## II. GENERAL PRESENTATION

Fig.1 shows a block diagram of our system. The acquisition card AD8232-EVALZ receives weak analogic ECG signals through three electrodes. The data are then amplified, filtered and digitalized using a microcontroller PIC12LF1840, and then it transmitted to the PC via the Bluetooth module RN20.

### A. ECG Signal Characteristics

ECG is electrical signal from cardiac muscle which is recorded to predict the abnormality present in the heart. ECG signal have of low amplitude, superimposed on high voltage and noise [9]. The noises are produced by skin-electrode contacts, muscle contraction (electromyography), patient respiration, the patient movement, 50 Hz component, the electromagnetic interference from another electric devices. To reduce the noise from skin-electrode contacts, Ag/AgCl electrodes are used.

<sup>1</sup> Laboratoire d'Analyse et de Modélisation des Phénomènes Aléatoires (L.A.M.P.A), Département of Electronics, University of Mouloud Mammeri, BP 17 RP, Tizi Ouzou, Algeria.

<sup>2</sup> LABSTICC, Ecole Nationale Supérieure de Techniques Avancées (ENSTA) Bretagne, Rue F. Verny 29200 Brest, France

<sup>3</sup> Hôpital d'Instruction des Armées, Rue Colonel Fonferrier, 29200 Brest, France

E-mails: [k\\_bensafia@ummto.dz](mailto:k_bensafia@ummto.dz), [mansour@ieee.org](mailto:mansour@ieee.org),  
[gilles.le\\_maillot@ensta-bretagne.fr](mailto:gilles.le_maillot@ensta-bretagne.fr), [benoit.clement@ensta-bretagne.fr](mailto:benoit.clement@ensta-bretagne.fr),  
[olivier.reynet@ensta-bretagne.fr](mailto:olivier.reynet@ensta-bretagne.fr), [phil.ar@hotmail.fr](mailto:phil.ar@hotmail.fr), [haddab-salah@ummto.dz](mailto:haddab-salah@ummto.dz)

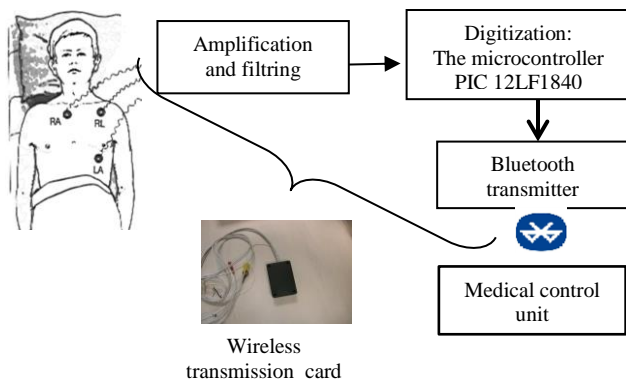

Fig. 1 Block diagram of the data acquisition system.

### A. The AD8232-EVALZ Printed Circuit Board

Our system is based on the AD8232-EVALZ (Fig.2) circuit. That regroups several modules: a buffer, an amplifier and a filter. The AD8232-EVALZ can be configured for two or three electrodes. In our case, we opted for three electrodes, one of them is used as an electrical reference. This card contains the integrated circuit AD8232 (Fig.3) [8] that is an integrated signal conditioning unit for biomedical signals. It is designed to extract, amplify and filter weak noisy biomedical signals.

The signal picked up by the electrodes is first passed through a cascade of two first order low-pass filter to remove line noise and other interference signals, and then connected to a differential amplifier of the integrated circuit AD8232 as show in Fig. 4.

The instrumentation amplifier in AD8232 behaves simultaneously as a gain enhancer and as a high pass filter for eliminating motion artifacts and the electrode half-cell potential.

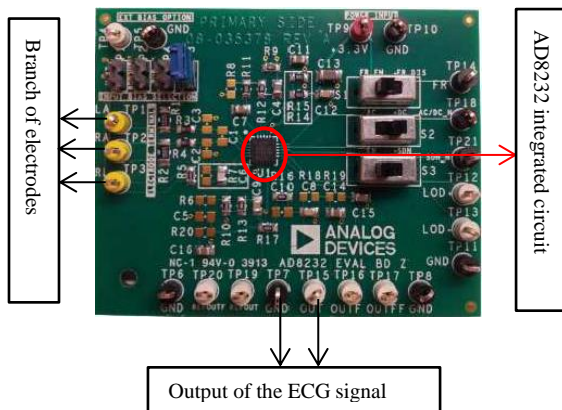

Fig. 2 The AD8232-EVALZ printed circuit board

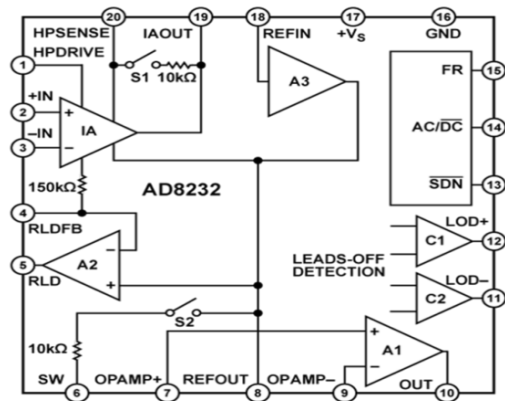

Fig. 3 Block diagram of AD8232

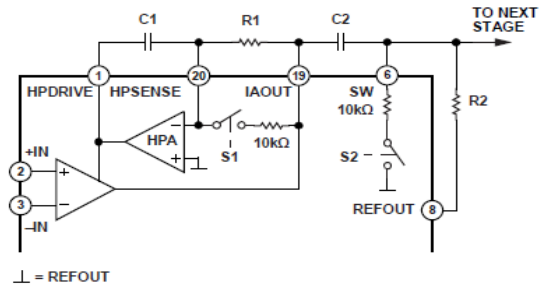

Fig. 4 The operational amplification

### B. CAN and Transmission Block

After the amplification and filtering procedure of our signal, the outcomes of the card AD8232-EVALZ represent directly an exploitable cardiac signal. The obtained analog signal is then converted to digital ones using an ADC (Analogue to Digital Conversion) based on PIC12LF1840 microcontroller [10]. It is well known that the normal heart rate of on healthy adult person should be between 60 and 100 beats per minute which corresponds to a frequency that varies between 1 and 1.7 Hz, this frequency increases with any physical effort of the subject, we should emphasizing that the heart rate of foteus or new born babies could reach 3 Hz. It is worth mention here that the heart beat, it is not the only maximum frequency existing in the cardiac signal. In fact, the heart beat represent the major peak of the signal; however in many clinic cases, physicians are in need to see and analyse the wave form of the cardiac signal such as the wave P, Q, R, S or T. Using different sampling frequencies to represent the cardiac signals and based on the feed backs of medical specialists, we found that 90 Hz is large enough to represent a good cardiac signal, therefore we set the sampling frequency  $F_s = 200Hz \geq 2 * 90Hz$ .

The maximum amplitude is 2.5 mV, and the minimum amplitude is -0.12 mV. Now another crucial question should be addressed how much bits should be considered to represent the dynamic behavior of the signal (i.e quantize the signal on M levels), we decide to have about a 1000 levels of quantization therefore each sample is quantified with 10 bits, and transmitted via Bluetooth using the RN20 module.

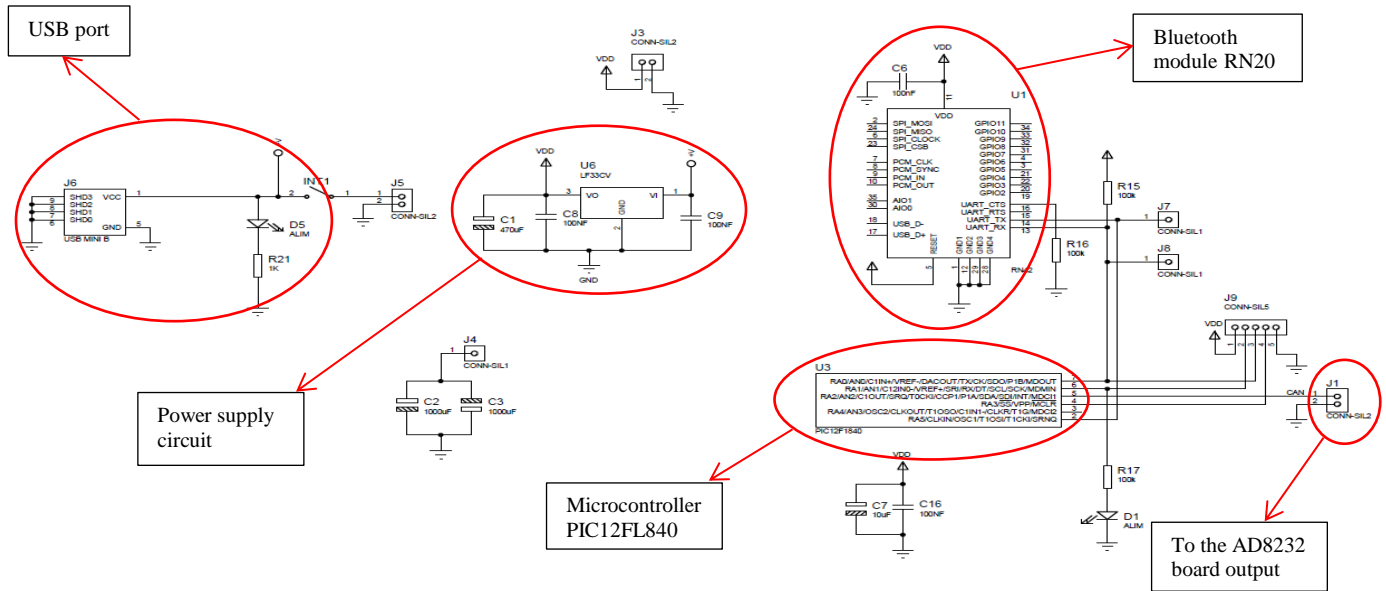

Fig.5 The digitalization and transmission block

The two printed circuits are powered by a single 3.7V battery of which is directly rechargeable via an USB port. Fig.5 shows the electrical diagram of the CAN and the transmission block where the connections among the Bluetooth module RN20, the PIC12FL1840 microcontroller, the power supply circuit, the AD8232-EVALZ board output and the USB port are mentioned. In the operating room, we observed disturbance coming from the electric bistoury appearing on the screen of the both devices.

### III. SIGNALS ANALYSIS AND EXPERIMENTATION RESULTS

In order to confirm the reliability of this card, a comparison between the two signals, that obtained by the classical device (S FL) and that obtained by our Bluetooth card (S BT) as show in Fig.6, is proposed. The comparison is done using the morphology of the two signals and the durations of the various waves (P and T waves and QRS complex), and the position of the ST segment with respect to the isoelectric line. The comparison is made over several periods and patients.

#### C. Pre-processing of Signals

The signals picked up by the conventional device (S FL) are sampled at a very high frequency (from 1 KHz to 60 KHz). While the signals obtained by our card (S BT) are sampled at a frequency of 200Hz, to reduce the computing and transmission times.

#### D. Synchronization of Signals and Durations of Different Waves

The two signals are not synchronized. To synchronize them, we generated an artifact by gently hitting the skin of the patient near the electrodes (see Fig.7).

To find the durations of the QRS complex, first the maximum value of the squared signal is determined, then the two first values left and right that cancel the signal are found ( $t_1$ ,  $t_2$ ). The difference between these two values corresponds

to the duration of the desired wave (Fig.8).

#### E. Statistical Approach

To compare the wave duration of the two signals, the Bland Altman graph [11] is performed.

Let:  $X = x_1 \dots \dots \dots x_n$ , the vector given the values measured by our device, and  $Y = y_1 \dots \dots \dots y_n$ , the vector of the values measured by the conventional system.  $n$  refers to the number of patients. The average and the difference are calculated between  $X$  and  $Y$ :

$$M_i = (x_i + y_i)/2 \quad (1)$$

$$D_i = x_i - y_i \quad (2)$$

Whith  $i \in [1 \ n]$ .

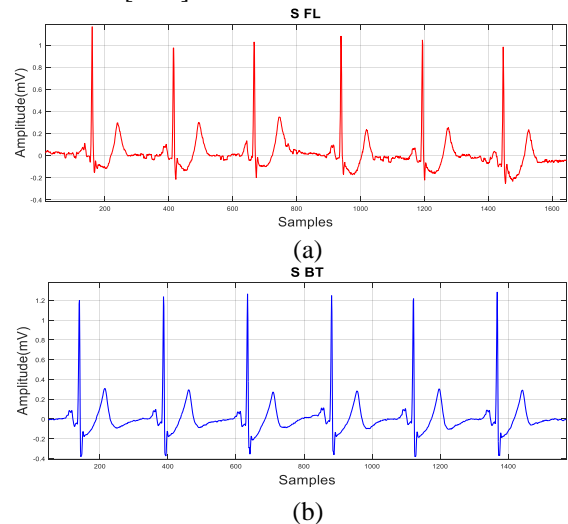

Fig.6 Signal obtained by the conventional (a), signal obtained by our system device (b)

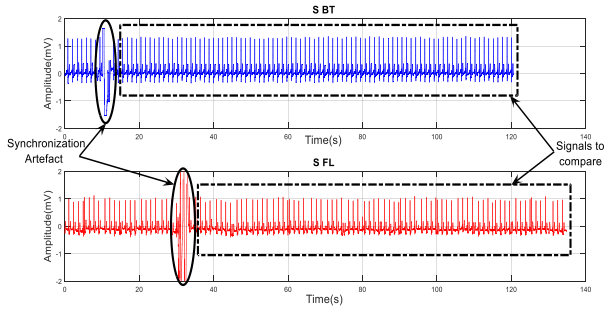

Fig.7 Synchronization of signals

Let us suppose that  $x_i$  and  $y_i$  are the noisy measurement of a real value. In this case, we can write:

$$x_i = V_i + \delta_a \quad (3)$$

$$y_i = V_i + \delta_b \quad (4)$$

Where  $\delta_a$  and  $\delta_b$  are the noises on the devices, then M and D can be rewriting as:

$$M_i = V_i + \frac{\delta_a + \delta_b}{2} \quad (5)$$

$$D_i = x_i - y_i = \delta_a - \delta_b \quad (6)$$

Without loss of generality, the noise  $\delta_a$  and  $\delta_b$  are supposed Gaussian, so  $D$  follows  $\mathcal{N}(d, \sigma^2)$ . Where  $\sigma$  represents the standard deviation and  $d$  the average of differences.

$$d = \frac{1}{n} \sum_{i=1}^n D_i \quad (7)$$

$$\sigma = \frac{\sqrt{\sum_{i=1}^n (D_i - d)^2}}{\sqrt{n}} \quad (8)$$

The 95% confidence interval  $I$  defined as follows [12]:

$$I = [d - 1.96 * \sigma / \sqrt{n}, d + 1.96 * \sigma / \sqrt{n}] \quad (9)$$

To say that the two apparatuses are concordant across the Bland Altman graph, it is necessary that most of the values must be within the confidence interval  $I$ . To plot the results of several patients on a single graph, we should normalize all obtained images such as their  $I$  becomes between  $[-1, +1]$ . This interval is represented by the red lines in graphs.

We have notice that the majority of points are within this range for all P, T waves and QRS complex, for one patient during 44 cycles (Fig.9).

Fig.10 to Fig.12 represent graphs for the P, T wave and the QRS complex respectively for five patients. They show that the larger number of the points located within red lines.

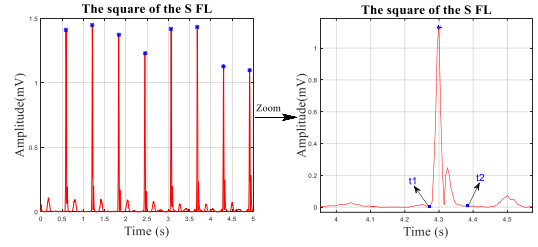

Fig. 8 QRS complex duration

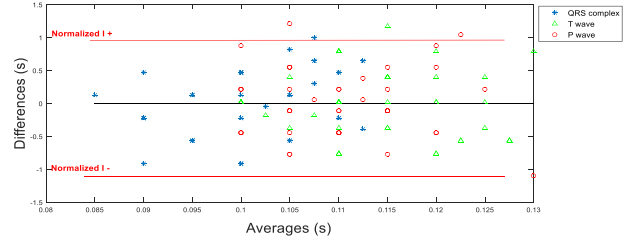

Fig. 9 P, T, QRS wave's durations for 1 patient during 44 cycles

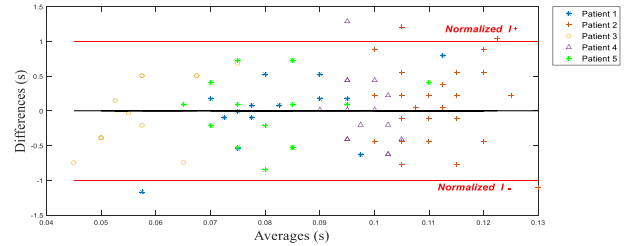

Fig. 10 Duration of P wave of 5 patients

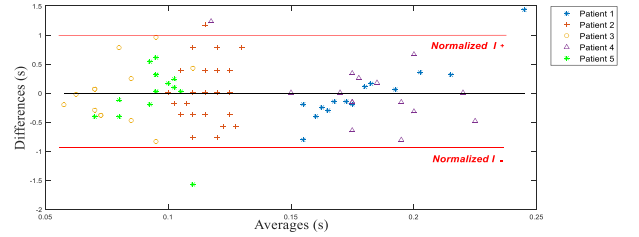

Fig. 11 Duration of T wave of 5 patients

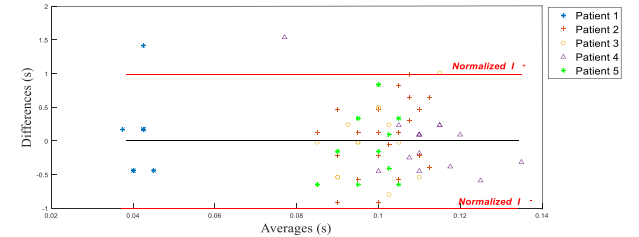

Fig. 12 Duration of QRS complex of 5 patients

These results confirm the agreement between the measurements obtained by our apparatus and those captured by the conventional apparatus.

The positions of ST segments with respect of baseline during 20 cycles are evaluated.

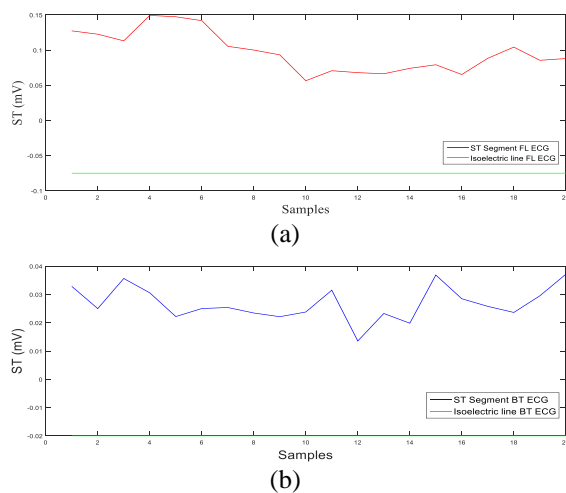

Fig.13 ST positions for S FL (a), ST positions for S BT (b)

Fig.13 shows that the position of the mean for each segment is above comparing to the isoelectric line for both signals.

#### IV. CONCLUSION

To secure a continuous monitoring of the heart health during surgery and when transferring patient from different blocs of the hospital, we have designed a wireless continuous monitoring system based on Bluetooth transmission. This system consists of the AD82232-EVALZ card, a PIC 12LF1840 microcontroller, a Bluetooth RN20 module and a rechargeable battery via an USB port.

The reliability of our system is tested by comparing signals captured by the designed device with those obtained by the conventional apparatus during surgery. This comparison is based on ECG signal morphology, P and T waves and QRS complex duration. We also compared the position of the ST segment with respect to the isoelectric line. The statistical approach applied on several patients confirms the agreement between the two devices. Our experimental results showed that the versatile proposed system could work stably and accurately.

#### REFERENCES

- [1] K. Øyri, I. Balasingham, E. Samset, J.O. Høgetveit, and E. Fosse, "Wireless Continuous Arterial Blood Pressure Monitoring During Surgery: A Pilot Study," *Anesthesia and Analgesia*, vol. 102, no. 2, pp. 478-483, 2006.
- [2] M. W. Gifari and H. Zakaria, "Design of ECG Homecare: 12-Lead ECG Acquisition using Single Channel ECG Device Developed on AD8232 Analog Front End," 5<sup>th</sup> International Conference on Electrical Engineering and Informatics, Bali, Indonesia, pp. 371-376, August, 2015.
- [3] D.P. Morales, A. Garcia, E. Castillo, M.A. Carvajal, J. Banqueri and A.j. Palma, "Flexible ECG acquisition system based on analog and digital reconfigurable devices," *Sensors & Actuators A:Physical*, vol. 165, no. 2, pp. 261-27, 2011
- [4] J. Hailong and M. Bing, "Design of Holter ECG System Based on MSP430 and USB Technology," In *Bioinformatics and Biomedical Engineering*, the 1st International Conference, Wuhan, China, pp.976-979, July, 2007.
- [5] S. Haddab and M. Laghrouche, "Microcontroller-Based System for Electrogastrography Monitoring Through Wireless Transmission," *Measurement Science Review*, vol. 9, no. 5, pp. 122-126, 2009.

- [6] C. Wei-Chen, C. Yi-Chung, C. Chia-Ching and F. Wai-Chi, "An EEG analog front-end design with wireless communication module for a portable EEG monitoring system," 5<sup>th</sup> International Conference on Consumer Electronics-Berlin, pp. 50-51, 2015.
- [7] H. Md Kamrul, R. Rushdi Zahid, H. Toufiq Md, G. Tarun Kanti. and A. Mohiuddin, "Design and simulation of cost effective wireless EEG acquisition system for patient monitoring," International Conference on Informatics, Electronics & Vision, Bangladesh, pp. 1-5, 2014.
- [8] Analog Device, "Single Lead, Heart Rate Monitor Front End," AD8232 data Sheet, 2012.
- [9] K. Bensafia, A. Mansour and S. Haddab, "Blind Source Subspace Separation and Classification of ECG Signals," 5<sup>th</sup> Internationale Conference en Automatique & Traitement de Signal, Sousse, Tunisia, March, 2017.
- [10] Microchip, PIC 12LF1840 data sheet, 2011.
- [11] D. G. Altman and J. M. Bland, "Measurement in medicine: the analysis of method comparison studies," *The statistician*, pp. 307-317, 1983.
- [12] A. Mansour, "Probabilités et statistiques pour les ingénieurs cours, exercices et programmation," Lavoisier, ISBN 978-2-7462-1936-6, Paris, 2007.